

Surface Mount Ball Bearing Assemblies



IEM



Surface Mount Ball Bearing Guide Post Assembly

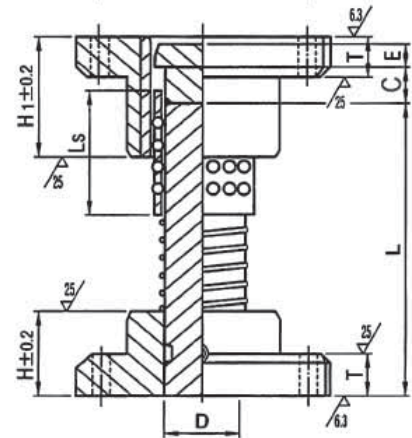
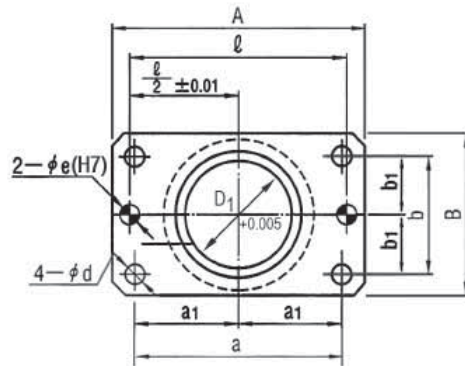

TAPPING FOR FIXING STROKE END BLOCK

D	M	ℓ1	S
32	4	12	45
38	5	15	60
50	6	15	72
60	8	20	92

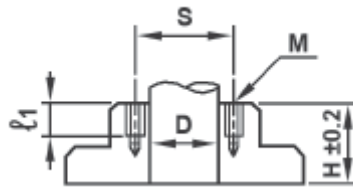

- NOTES:**
- ◆ Add "M" to end of part number to designate mounting holes option for optional stroke end blocks.
 - ◆ Assemblies are supplied with mounting bolts and dowel pins.

Anchor Danly Part Number	D	L	D1	A	B	a	b	d	H	H1	T	C	E	Ls	ℓ	a1	b1	e (H7)	Mounting Bolts	Dowel Pins
ADGPS32X110	32	110	40	100	58	76	36	11	40	60	20	25	5	60	76	38	18	8	10 x 1.5 x 40mm	8 - 30
ADGPS32X120		120																		
ADGPS32X130		130																		
ADGPS32X140		140																		
ADGPS32X150		150																		
ADGPS32X160		160																		
ADGPS32X170	170																			
ADGPS38X130	38	130	48	130	75	100	44	11	50	70	25	30	10	70	100	50	22	10	10 x 1.5 x 45mm	10 - 40
ADGPS38X140		140																		
ADGPS38X150		150																		
ADGPS38X160		160																		
ADGPS38X170		170																		
ADGPS38X180		180																		
ADGPS38X200		200																		
ADGPS38X220		220																		
ADGPS38X240		240																		
ADGPS38X260		260																		
ADGPS38X300	300																			
ADGPS50X170	50	170	60	155	90	125	60	14	65	90	25	40	10	90	125	62.5	30	10	12 x 1.75 x 50mm	10 - 40
ADGPS50X180		180																		
ADGPS50X200		200																		
ADGPS50X220		220																		
ADGPS50X240		240																		
ADGPS50X260		260																		
ADGPS50X300		300																		
ADGPS50X350	350																			
ADGPS60X200	60	200	70	190	120	150	80	18	75	100	30	50	15	100	150	75	40	13	16 x 2 x 60mm	13 - 50
ADGPS60X220		220																		
ADGPS60X240		240																		
ADGPS60X260		260																		
ADGPS60X280		280																		
ADGPS60X300		300																		
ADGPS60X350		350																		

Stroke End Blocks – Flat Type & Nesting Step Type

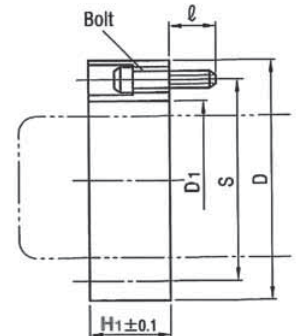
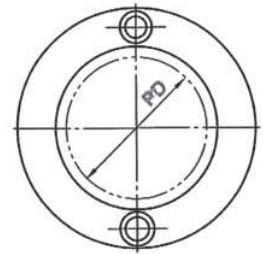

FLAT TYPE

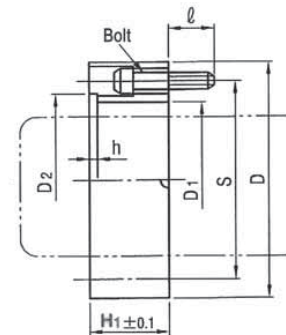
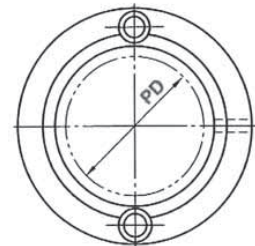

NESTING STEP TYPE

Anchor Danly Part Number		PD	D	D1	D2*	S	h*	Bolt	l	H1
Flat Type	Nesting Step Type									
SEBA3210R	SEB3210R	32	56	41	45	45	2	M4xP0.7	10	10
SEBA3215R	SEB3215R									15
SEBA3220R	SEB3220R									20
SEBA3225R	SEB3225R									25
SEBA3230R	SEB3230R									30
SEBA3235R	SEB3235R									35
SEBA3240R	SEB3240R									40
SEBA3245R	SEB3245R									45
SEBA3250R	SEB3250R									50
—	SEB3255R									55
—	SEB3260R	60								
SEBA3815R	SEB3815R	38	72	49	56	60	3	M5xP0.8	10	15
SEBA3820R	SEB3820R									20
SEBA3825R	SEB3825R									25
SEBA3830R	SEB3830R									30
SEBA3835R	SEB3835R									35
SEBA3840R	SEB3840R									40
SEBA3845R	SEB3845R									45
SEBA3850R	SEB3850R									50
—	SEB3855R									55
—	SEB3860R									60
—	SEB3865R	65								
—	SEB3870R	70								
SEBA5020R	SEB5020R	50	86	62	68	72	3	M6xP1.0	10	20
SEBA5025R	SEB5025R									25
SEBA5030R	SEB5030R									30
SEBA5035R	SEB5035R									35
SEBA5040R	SEB5040R									40
SEBA5045R	SEB5045R									45
SEBA5050R	SEB5050R									50
—	SEB5055R									55
—	SEB5060R									60
—	SEB5065R									65
—	SEB5070R	70								
—	SEB5075R	75								
—	SEB5080R	80								
SEBA6020R	SEB6020R	60	112	76	84	92	3	M8xP1.25	12	20
SEBA6025R	SEB6025R									25
SEBA6030R	SEB6030R									30
SEBA6035R	SEB6035R									35
SEBA6040R	SEB6040R									40
SEBA6045R	SEB6045R									45
SEBA6050R	SEB6050R									50
—	SEB6055R									55
—	SEB6060R									60
—	SEB6065R									65
—	SEB6070R	70								
—	SEB6075R	75								
—	SEB6080R	80								

* Dimensions for Nesting Step Block ONLY.

Selection Guide

Selection Guide for Anchor Danyl Surface Mount Guide Post System

The following points should be considered when selecting Surface Mounted Ball Bearing Assemblies:

- ◆ At the bottom of the press stroke (**BDC**), the length of the preloaded ball bearing engagement should be equal to or greater than the guide post diameter (**D**) for proper guidance and stability (Fig. 6).
- ◆ $h_2 = L + C + E + 10\text{mm}$ (Fig 1) – 10mm is to allow for regrinding and safety considerations.
For **C + E**, see Page 2.
- ◆ How to determine **K** (minimum Punch Holder thickness): Reference (Fig. 1) and the blue chart (Page 4).
- ◆ Example: If $h = 190\text{mm}$ and you select an ADGPS38X200 assembly, from the blue table (Page 4), ADGPS38X200 would have an h_2 dimension of 250mm.
 $250\text{mm} - 190\text{mm} (h) = 60\text{mm}$.
K is required to be 60mm or greater.
- ◆ As shown in (Fig. 3), select guide post length so (**h**) includes as much contact length (**PL**) as possible.

Use the figures below for reference when using the tables on Page 4.

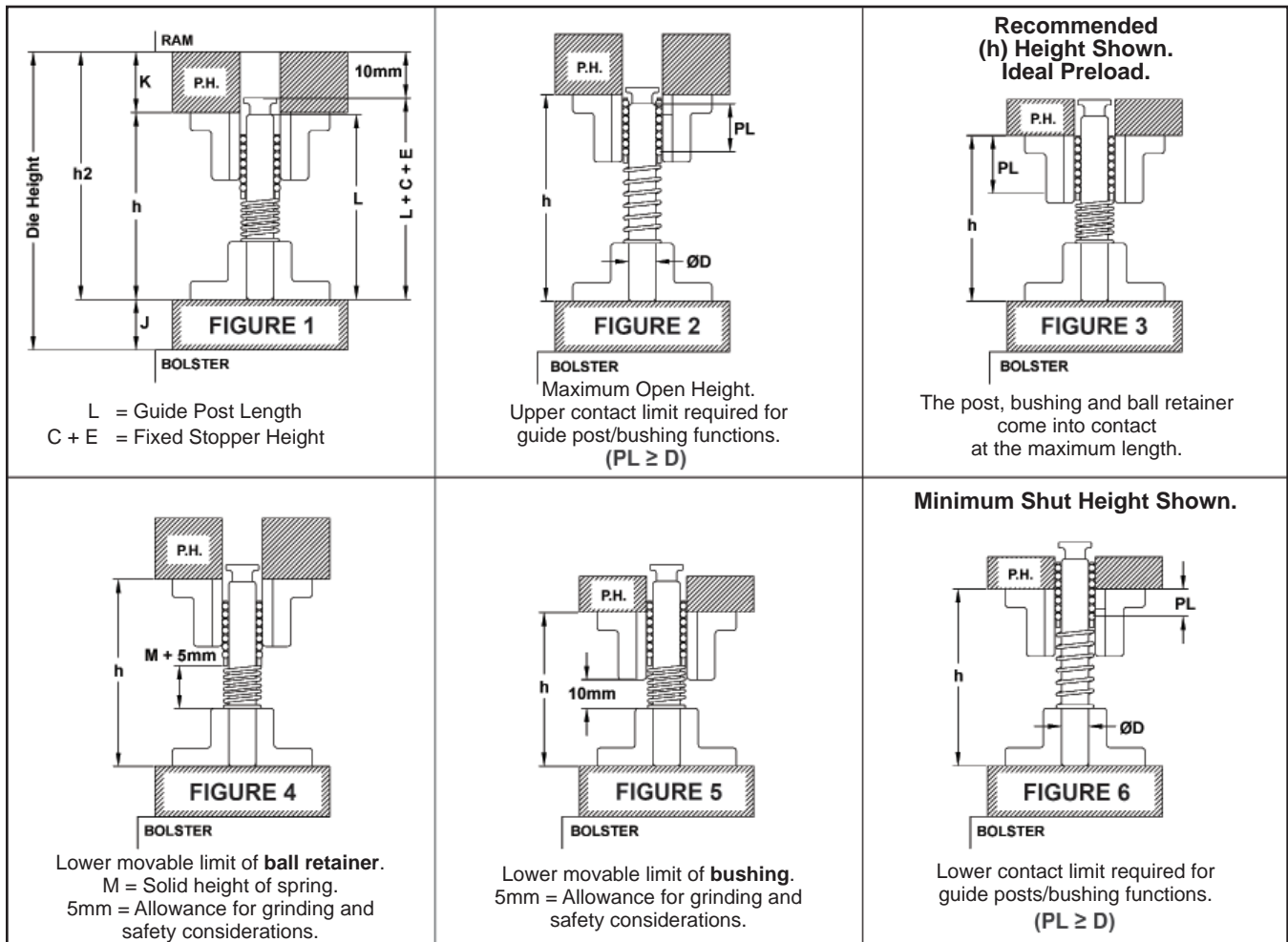

K = Punch Holder Thickness

J = Die Holder Thickness

L = Guide Post Length

D = Guide Post Diameter

C + E = Fixed Stopper Length

PL = Length of Ball Cage in Preload Condition

M = Spring Height to Solid

Effective Fitting Range

Based on Conditions Shown on Page 4, Figs. 2 – 6

The tables below show:

- Shaded blue cells below show workable range of travel of assembly through stroke.
- To the left end of shaded blue cells shows minimum inside die height of assembly on closed.
- To the right of that, shaded blue cells shows inside die height through range of travel.
- To the far right of shaded blue cells shows inside die height at end of workable travel.

Post Size (D)(L)	Die Height (h)													h ₂	
	100	120	140	160	180	200	220	240	260	280	300				
32	110			▲	★										150
	120		▲	●	★										160
	130		◆	●	★										170
	140		◆	●	★										180
	150		◆	●	★										190
	160		◆	●	★										200
	170		◆	●	★										210

Post Size (D)(L)	Die Height (h)													h ₂
	120	140	160	180	200	220	240	260	280	300	320	340	360	
38	130		▲	★										180
	140		▲	★										190
	150		◆	●	★									200
	160		◆	●	★									210
	170		◆	●	★									220
	180		◆	●	★									230
	200		■	●	★									250
	220			■	●	★								270
	240				■	●	★							290
	260					■	●	★						310
	300						■	●	★					350

Post Size (D)(L)	Die Height (h)													h ₂
	160	180	200	220	240	260	280	300	320	340	360	380	400	
50	170		▲	★										230
	180		▲	★										240
	200		◆	●	★									260
	220		◆	●	★									280
	240		◆	●	★									300
	260		■	●	★									320
	300			■	●	★								360
	350				■	●	★							410

Post Size (D)(L)	Die Height (h)													h ₂
	180	200	220	240	260	280	300	320	340	360	380	400	420	
60	200		▲	★										275
	220		▲	★										295
	240		◆	●	★									315
	260		◆	●	★									335
	280		◆	●	★									355
	300		■	●	★									375
	350			■	●	★								425

NOTE: Symbols shown in the above tables are for reference only.

- ★ (Fig. 2) Upper contact limit required on **open**
- (Fig. 3) **Ideal preload** recommended (h) shown
- ▲ (Fig. 4) Lower movable limit of **Ball Retainer**
- ◆ (Fig. 5) Lower movable limit of **Bushing**
- (Fig. 6) Lower contact limit required on **closed**

Replacement Items



Replacement End Cap

Replacement Ball Bearing Retainer

Replacement Spring

Replacement Bolt and Dowel Kits

Complete Assembly Number	Replacement Springs	Nominal Pin Size	Spring ID	Spring OD	Spring Length	Replacement Ball Bearing Retainers	Replacement End Caps (FIXED STOPPER) w/ Bolt	Replacement Bolt & Dowel Kits						
ADGPS32X110	SPR32X110	32	32.5	35.7	60	ASM32-060-4	STR-F32 (M8-40 SHCS)	ADGPS-BD-KIT-32 (8) 10 x 1.5 x 40mm bolts (4) 8-30 Dowel						
ADGPS32X120	SPR32X120				60									
ADGPS32X130	SPR32X130				80									
ADGPS32X140	SPR32X140				80									
ADGPS32X150	SPR32X150				100									
ADGPS32X160	SPR32X160				100									
ADGPS32X170	SPR32X170				120									
ADGPS38X130	SPR38X130	38	38.5	42.5	60	AMS38-070-5	STR-F38 (M8-50 SHCS)	ADGPS-BD-KIT-38 (8) 10 x 1.5 x 45mm bolts (4) 10-40 Dowel						
ADGPS38X140	SPR38X140				80									
ADGPS38X150	SPR38X150				80									
ADGPS38X160	SPR38X160				100									
ADGPS38X170	SPR38X170				100									
ADGPS38X180	SPR38X180				120									
ADGPS38X200	SPR38X200				140									
ADGPS38X220	SPR38X220				160									
ADGPS38X240	SPR38X240				180									
ADGPS38X260	SPR38X260				200									
ADGPS38X300	SPR38X300				240									
ADGPS50X170	SPR50X170				50				50.5	55.7	100	AMS50-090-5	STR-F50 (M8-65 SHCS)	ADGPS-BD-KIT-50 (8) 12 x 1.75 x 50mm bolts (4) 10-40 Dowel
ADGPS50X180	SPR50X180										100			
ADGPS50X200	SPR50X200	120												
ADGPS50X220	SPR50X220	140												
ADGPS50X240	SPR50X240	160												
ADGPS50X260	SPR50X260	180												
ADGPS50X300	SPR50X300	220												
ADGPS50X350	SPR50X350	280												
ADGPS60X200	SPR60X200	60	60.5	66.9	120	AMS60-100-5	STR-F60 (M8-75 SHCS)	ADGPS-BD-KIT-60 (8) 16 x 2 x 60mm bolts (4) 13-50 Dowel						
ADGPS60X220	SPR60X220				140									
ADGPS60X240	SPR60X240				160									
ADGPS60X260	SPR60X260				180									
ADGPS60X280	SPR60X280				200									
ADGPS60X300	SPR60X300				220									
ADGPS60X350	SPR60X350				280									

Ball Bearing Lubrication



Component maintenance is serious business... Always use Lamina Ball-Lube® and Ball-Scrubb® to keep ball-bearing components clean and running smooth.

Product Features

BALL-SCRUBB® removes heavy soils, dirt or grease from ball-bearing guide pin assemblies. Just spray it on... wait three minutes... and spray again. Then blow off excess with compressed air. **BALL-SCRUBB®** is an industrial strength cleaner with rust inhibitors, specially formulated to clean debris and grease from all types of ball-bearing assemblies.

BALL-LUBE®, when applied after **BALL-SCRUBB®**, locks out wear by chemically bonding to precision surfaces. It provides a tough, long-lasting shield that protects against oxidation and rust. **BALL-LUBE®** lubricates assemblies and gives them long-time protection against wear, oxidation and heat. Spray liberally on ball-bearing assemblies.

Part Number	BALL-LUBE® Size
ARL016	Pint BALL-LUBE® spray
ARL384	Case (24) 1 Pint BALL-LUBE®
ARL128	Gallon BALL-LUBE®
ARL640	Gallons BALL-LUBE®

Part Number	BALL-SCRUBB® Size
ARS016	1 Pint BALL-SCRUBB® Spray
ARS384	1 Case (24) 1 Pint BALL-SCRUBB®
ARS128	1 Gallon BALL-SCRUBB®
ARS640	5 Gallons BALL-SCRUBB®

Die Lubrication

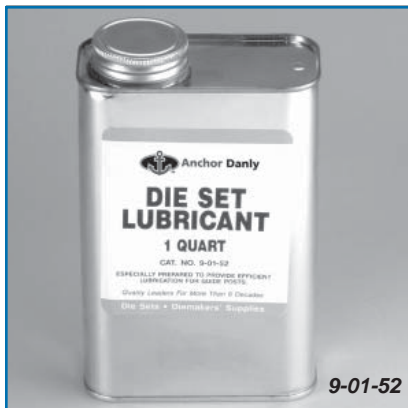

Product Features

This die lubricant is specially prepared to provide efficient lubrication for guide posts in plain bearing applications.

Part Number	Size
9-01-52	1 Quart
9-02-52	1 Gallon
9-02-521	55 Gallons
9-02-522	15 Gallons

Distributed by:



OUTSIDE THE USA & CANADA:

CALL: 001-248-489-7816

FAX: 001-248-553-6842

EMAIL: info@anchordanly.com

www.anchordanly.com

